

SFC.

Breather cap with sealing closure

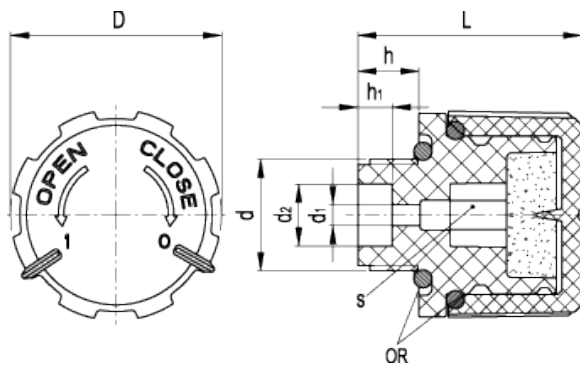

ELESA Original design



american unit
metric unit

Elesa Standards		Main dimensions								Weight
Code	Description	d	h	D	L	d ₁	d ₂	h ₁	s	lbs g
52801	SFC.30-3/8+F	- G 3/8	0.35 9	1.18 30	1.3 33	0.12 3	0.35 9	0.2 5	0.31 8	0.04 18

Cover

Polyamide based (PA) technopolymer. Resistant to solvents, oils, greases and other chemical agents.

Threaded connector

Acetal based technopolymer (POM).

Colour

Black, semi-matte finish.

Packing rings

NBR synthetic rubber O-Ring.

Air filter

Polyurethane foam mesh "tech-foam" (polyester base), air filtration 10 µ.

Maximum continuous working temperature

175°F (80°C).

Special executions on request (For sufficient quantities)

- Air filter in polyurethane foam mesh "tech-foam" (polyester based) with air filtration 40 µ.
- Cover in RAL 2004 orange.

Features and applications

The cover of the SFC. breather cap offers two different closure modes:

- Sealing closure: the cap is completely clamped and closed. The packing ring between the cover and the threaded connector flange guarantees a perfect sealing of gas or liquid contained in the reservoir.
- Breather closure: air is let in and out of the reservoir in normal conditions of use.

Assembly instructions

- 1) Screw the threaded connector by means of a hexagon key, maximum tightening torque: 6 ft-lb (8 Nm) (fig. 1).
- 2) Insert the "tech-foam" filter in its proper upper housing.
- 3) Fit the cover on the threaded connector by properly matching the two different teeth (different for shape) of the cover and the relevant knurling on the upper part of the threaded connector (fig. 2). On this knurling there are two stop positions, where the teeth of the cover are fitted: one is for the breather closure and the other one is for the sealing closure.
- 4) Breather closure. After fitting the cover (see point 3), turn it following the CLOSE arrow (clockwise) until the first click. In this position the cover is locked by means of the teeth fitted in the relative stop housing of the knurling: this is a guarantee against accidentally unscrewing. In this position the index on the cover marked with 1 is in line with the index on the flange of the threaded connector (fig. 3).
- 5) Sealing closure. To reach sealing closure from breather closure (see point 4), turn the cover following the CLOSE arrow (clockwise) until the click. In this position the cover is locked by means of the teeth fitted in the relative stop housing of the knurling: this is a guarantee against accidentally unscrewing. In this position the index on the cover marked with 0 is in line with the index on the flange of the threaded connector (fig. 4).
- 6) To reach breather closure (index on the cover marked with 1 in line with the index on the threaded connector) from sealing closure (index on the cover marked with 0 in line with the index on the threaded connector) just turn the cover following the OPEN arrow (anticlockwise) until the click (fig. 3).
- 7) By turning the cover following the OPEN arrow (anticlockwise), from breather closure it is possible to remove the cover from the threaded connector after the click, thus allowing the operator to clean the components or to substitute the "tech-foam" filter (fig. 5).

